



A Donaldson Company

A WORLD LEADER IN FUME EXTRACTION TECHNOLOGY

# FumeCAB 700

ELECTRONICS, PHARMACEUTICAL & MEDICAL

Last Updated on 12.04.2021



The complete solution for fume cabinet extraction for a broad range of applications.

Partial enclosures are becoming the recommended extraction option for a variety of applications. Government bodies, including the HSE in the UK are now making direct reference through guidance documentation such as the HSG258 to their use.

The FumeCAB 700 integrated filtration system has been designed to ensure compliance with the latest regulations. The innovative cam filter change design enables safe and simple front loading filter replacement and provides many benefits over alternative rear access systems.

Ultra-bright slim line energy saving LED lights come as standard with optional UV lighting, making the FumeCAB 700 an ideal choice for applications such as the conformal coating of PCBs, where operators can now easily identify uniformity issues with the coating.

## Technology



HEPA filter



Automatic flow control (AFC) technology (230v only)



Reverse flow air (RFA) technology



Advanced carbon filter (ACF) technology



ProTECT service plan



SureCHECK quality standard

## Key features of the FumeCAB 700

**Certified to BS 7989:2001 - recirculatory filtration fume cabinet specification**  
Standard

**Auto sensing flow control**  
Standard

**Twin coated anti UV / anti splash protective polycarbonate visor**  
Standard

**Large working area**  
Standard

**Audible and visual warning alarms**  
Standard

**VOC monitor**  
Optional

**Ensures operational compliance with HSG258 guidelines**  
Standard

**Energy saving ultra-bright slim line LED lighting**  
Standard

**Low noise level**  
Standard

**Side entry blind grommets for equipment access**  
Standard

**UV lighting**  
Optional

**Stand**  
Optional

Contact BOFA at <https://bofainternational.com/en/contact/>

<https://bofainternational.com/en/portal/datasheets/fumecab-700/>



## Technical specification

- |  |                             |                              |                          |
|--|-----------------------------|------------------------------|--------------------------|
| 1. Unit / filter condition display<br>- automatic flow control | 2. On / off switch          | 3. Filter compartment hinges | 4. Cable entry grommet   |
| 5. Transparent visor   | 6. Transparent visor hinges | 7. Power cable inlet         | 8. Internal LED lighting |
| 9. Exhaust outlet  | 10. LED/UV light switch     |                              |                          |

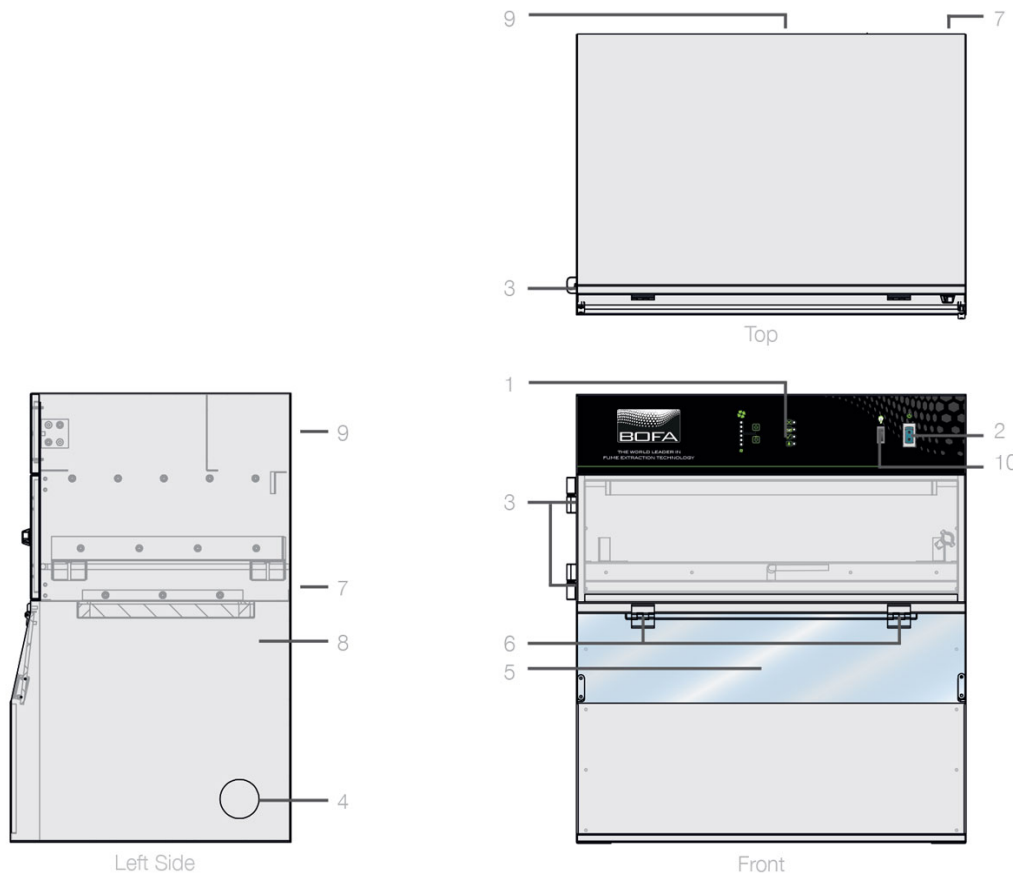

## Airflow through filter

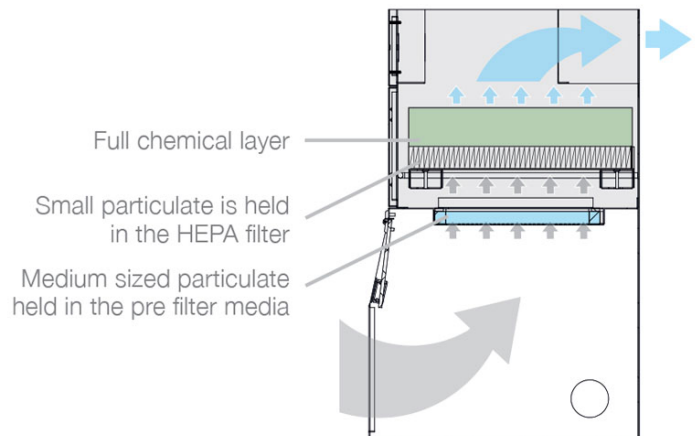
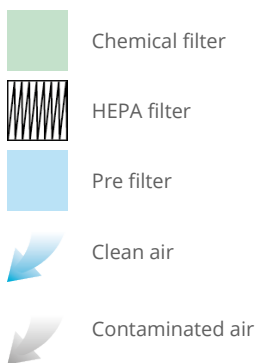

## Technical data

Product	EU	US
Dimensions (HxWxD)	780 x 700 x 490 mm	(30.71 x 27.56 x 19.29")
Opening dimensions (hwx)	675 x 225mm (26 x 8.8")	675 x 225mm (26 x 8.8")
Cabinet construction	Powder coated mild steel	Powder coated mild steel
Face velocity	0.4m/s (78.7ft/min)	0.5m/s (100ft/min)

## Technical data

Max face velocity	0.6m/s (118ft/min)	
Electrical data	230v 50/60Hz Full load current: 2 amps	115v 50/60Hz Full load current: 3 amps
Noise level	< 53dBA (at typical operating speed)	< 55dBA (at typical operating speed)
Weight	65kg	143lbs
Exhaust outlet (optional)	100mm	100mm
Approvals	UKCA and CE	UKCA and CE

## Pre-filter specifications

Filter media construction	Filter pad
Filter housing	Cardboard
Filter efficiency	99% @ 0.3 microns

## Combined HEPA / gas filter specifications

HEPA filter media	Borosilicate
HEPA media construction	Pleated with glue bead spacers
Filter housing	Zintec mild steel
Treated activated carbon	10kgs (22 lbs)
Filter efficiency	99.997% @ 0.3 microns

## Unit part numbers

Model	Voltage	Part no.	Optional UV lights	Optional VOC monitor	Optional stand
FumeCAB 700 Powder coated	230V	E2742A	A2009	A2003	A1060063
FumeCAB 700 Powder coated	115V	E2741A	A2009	A2003	A1060063

## Replacement filter part numbers

Description	Part number
Pre-filter	A1030269
Combined filter	A1030270



## Internal work area

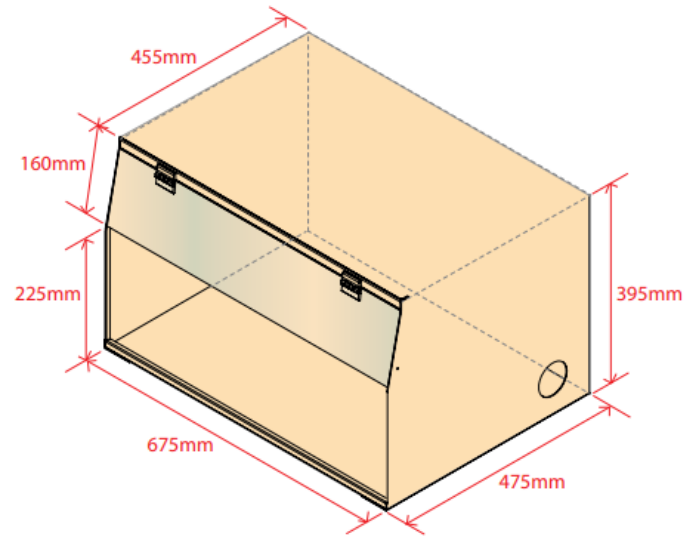

## Optional stand



### Optional stand specifications

Dimensions (HxWxD)

950 x 690 x 497mm / 37.4 x 27.16 x 19.56"

Stand construction

Powder coated mild steel

*Datasheet correct at time of publishing.*

*Where applicable, the carbon used in BOFA units is capable of removing a wide range of VOC's, however it is the responsibility of the user to ensure the carbon is suitable for their application. For specific applications, please contact us for details.*

*Think before you print! Please consider the environment before printing this document.*