



A WORLD LEADER IN FUME EXTRACTION TECHNOLOGY

# AD Cyclone

LASER, MECHANICAL ENGINEERING

Last Updated on 08.04.2021



Inline cyclone filter for heavy particulate, to extend filter life and extraction performance.

Most people are aware of cyclone separators thanks to Sir James Dyson and his vacuum cleaners.

Cyclone separators are useful at capturing particles of 20micron and larger, i.e. visible to the naked eye.

Unfortunately laser marking generates a wide range of particle sizes that are smaller than this so standard cyclone separators are not as efficient.

BOFA International commissioned the University of Southampton in the UK, using CFD (computational fluid dynamics) techniques, to develop a cyclone to operate more efficiently at these lower particle sizes.

The C5 Cyclone separator has been design specifically for use with the [AD Oracle iQ](#) extraction unit and is installed between the laser extraction point and the extractor. The airflow generated by the extraction unit powers the cyclone.

## Technology



ProTECT service plan



SureCHECK quality standard

Contact BOFA at <https://bofainternational.com/en/contact/>  
<https://bofainternational.com/en/portal/datasheets/ad-cyclone-2/>



## Technical specification

1. Air inlet connection - 75mm

2. Air outlet connection - 75mm

3. Capture pot

4. Cyclone chamber

5. Base

6. Shut off valve

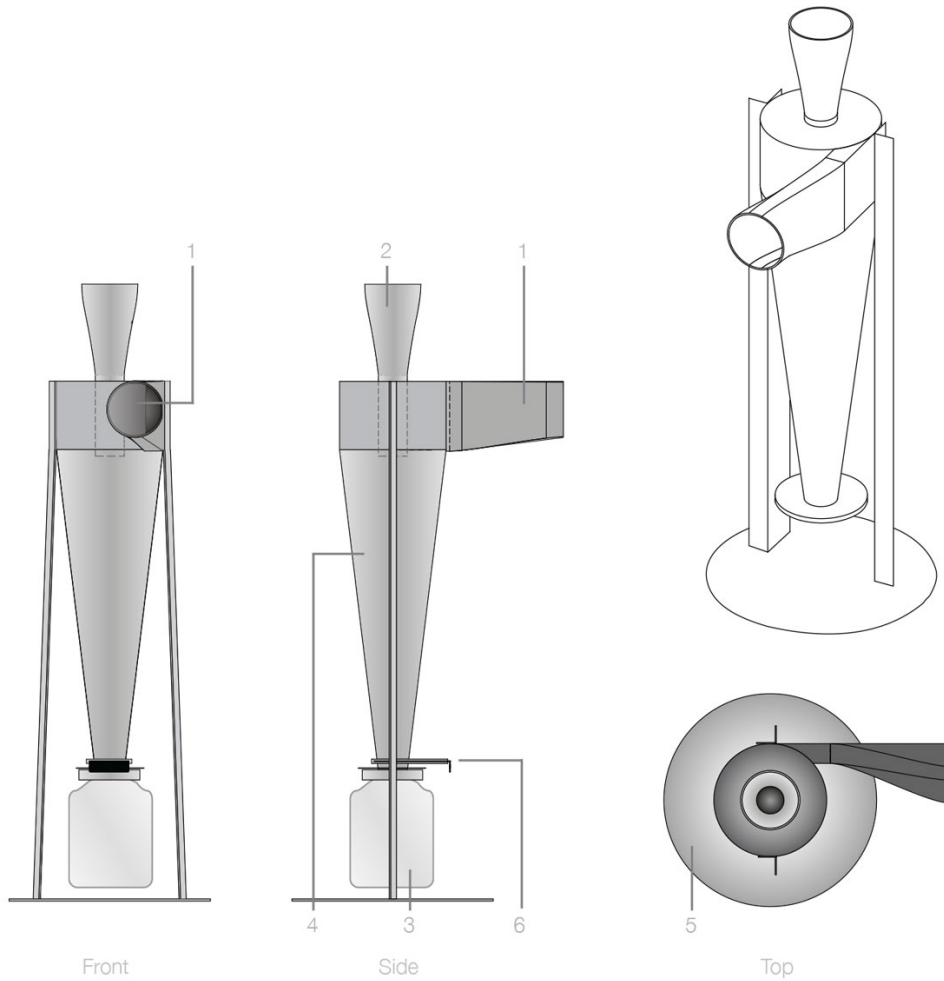

## Airflow through cyclone

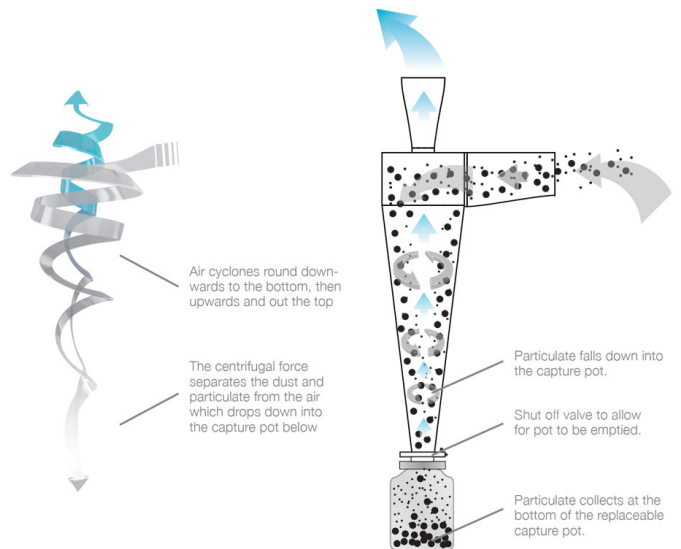
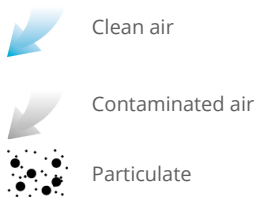

## Technical data

Dimensions (HxWxD)	800 x 300 x 140mm (31.5 x 11.81 x 5.51")
Construction	Stainless steel
Powered by	AD Oracle extraction unit
Weight	7kg / 15.4lbs

## Part numbers

Model	Part no.
AD Cyclone with shut off valve - Stainless steel	A1080112

## Other languages

AD Cyclone  
[French](#)

*Datasheet correct at time of publishing.*

*Where applicable, the carbon used in BOFA units is capable of removing a wide range of VOC's, however it is the responsibility of the user to ensure the carbon is suitable for their application. For specific applications, please contact us for details.*

*Think before you print! Please consider the environment before printing this document.*

