

Caxtool Kft.  
6791 Szeged, Dorozsmai út 157. EU  
+36 62 254 826  
+36 30 565 1812  
[d.zanocz@caxtool.hu](mailto:d.zanocz@caxtool.hu)  
[info@caxtool.hu](mailto:info@caxtool.hu)

Adószám: 12871856-2-06  
Adószám: HU 12871856  
Bankszámla száma: 57600101-11102986  
SWIFT (BIC): TAKBHUHB  
IBAN: HU65 57600101 11102986 00000000  
cégjegyzékszám: 06-09-014002  
info:

## Képgyűjtemény

Fiber lézervágó berendezés

**CAXTC\_LM\_3015\_1.5kW\_J\_1.0 fiber lézervágó berendezés / Fiber cutting machine**



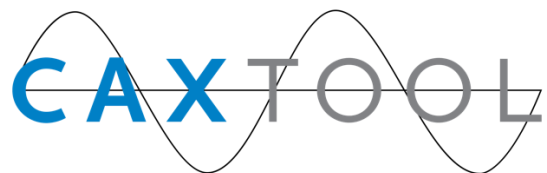

Caxtool Kft.  
6791 Szeged, Dorozsmai út 157. EU  
+36 62 254 826  
+36 30 565 1812  
[d.zanocz@caxtool.hu](mailto:d.zanocz@caxtool.hu)  
[info@caxtool.hu](mailto:info@caxtool.hu)

Adószám: 12871856-2-06  
Adószám: HU 12871856  
Bankszámla száma: 57600101-11102986  
SWIFT (BIC): TAKBHUHB  
IBAN: HU65 57600101 11102986 00000000  
cégjegyzékszám: 06-09-014002  
info:





Caxtool Kft.  
6791 Szeged, Dorozsmai út 157. EU  
+36 62 254 826  
+36 30 565 1812  
[d.zanocz@caxtool.hu](mailto:d.zanocz@caxtool.hu)  
[info@caxtool.hu](mailto:info@caxtool.hu)

Adószám: 12871856-2-06  
Adószám: HU 12871856  
Bankszámla száma: 57600101-11102986  
SWIFT (BIC): TAKBHUHB  
IBAN: HU65 57600101 11102986 00000000  
cégjegyzékszám: 06-09-014002  
info:



- **Machine Application**

Widely used in sheetmetal processing, aviation, aerospace, electronics, electrical appliances, automobile, food machinery, textile machinery, engineering machinery, precision parts, ships, metallurgy equipment, elevators, household appliances, craft gifts, tool processing, decoration, advertising, and other fields. Professional used to cut sheet metal like carbon/mildsteel, stainless steel, aluminum alloy, galvanized sheet, electrolytic plate, titanium alloy, aluminum zinc plate, etc.

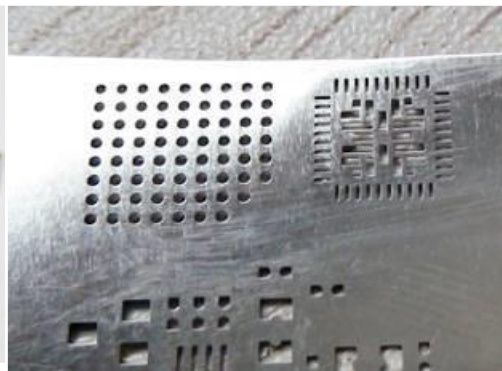

- **Lézer rezonátor / JPTCW 1500 Fiber Laser (1500W)**

JPT single mode fiber laser(500W-2000W) is the optimal combination of optical, mechanical, electrical and software components. Through the controlling ports and the controlling software, the operating status of the laser can be monitored in real time, alarm messages can be received in time, and data can be collected. The laser uses water-cooling and shelf case design, with competitive advantage like high energy conversion (electric to light), low power consumption, maintenance free, fiber delivery, and easy to assemble, it is the most suitable laser source for industrial laser welding, cutting and other applications.



	Unit	Parameter				
Nominal Average Output Power	W	500	800	1000	1500	2000
Beam Parameter Product	mm*mrad	<2 @50um				
Central Wavelength	nm	1080				
Spectral Width@3db	nm	<6				
Armored Cable Length	M	8			15	
Cooling Method		Water Cooled (Purified Water)				
Operating Voltage	V	Single-phase 220(AC)±10%			Three-phase 380(AC)±10%	
Maximum Power Consumption	W	1800	2700	3300	5000	7000
Switch on/off time	us	<20				
Maximum Modulation Frequency	khz	20				

Operation Temperature	°C	23 ~ 26	
Storage Temperature	°C	-20 ~50	
N.W	kg	36	83.5
Size (WxDxH)	mm	483 × 484 × 133	483 × 800 × 178

- **Raytools BM111 lézerfej**



BM111 series are auto focusing cutting head, which are released by Switzerland RAYTOOLS AG in 2017. The product has built-in motor drive unit through the linear driver and the focusing lens can automatically change the position in the range of 22mm. The user can set the focus continuously through the program to complete the rapid piercing of thick sheets or other different thickness and material sheets. The product can be equipped with D30 lens group to integrate the light beam. The optimization of optical design and the design of water-cooled allows laser heads stably and chronically to work at high power lasers.

- • Optimized optical configuration and smooth and efficient airflow design.
- • Auto focus ranges +9~-14mm, accuracy is 0.05mm.
- • Can be equipped with the D30 lens group, the maximum fiber input power is 3.3KW.
- • Maximum acceleration of focus lens drive 10m/s<sup>2</sup>, maximum speed 10m/min.
- • Adds an upper protective lens to the collimator, minimizing the risk of contamination of the collimator.
- • Drawer-type of lens mount, quick and easy access to the cover glass.
- • With a variety of optical interfaces, can be adapted with a variety of fiber lasers.

Power Rating	≤ 3.3KW
Clear Aperture	28mm
Collimator Focal length	100mm
Focusing Focal length	125mm/155mm/200mm
Collimating protective glass	φ 24.9mm*1.5mm



Focus protective glass	$\phi 27.9\text{mm} \times 4.1\text{mm}$
Auto focus range	+10~-12mm
Assist gas Pressure	$\leq 30\text{bar}$
Weight	$\sim 6.5\text{kg}$

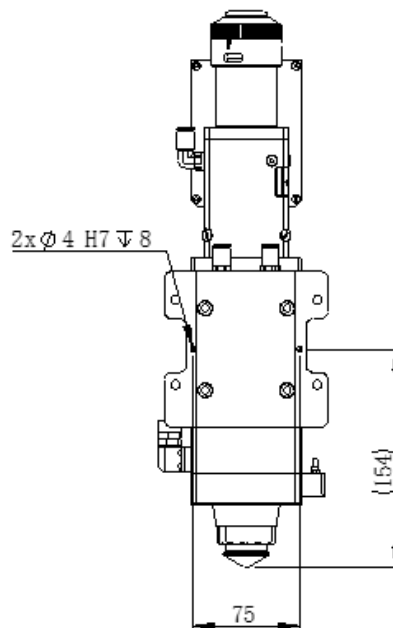
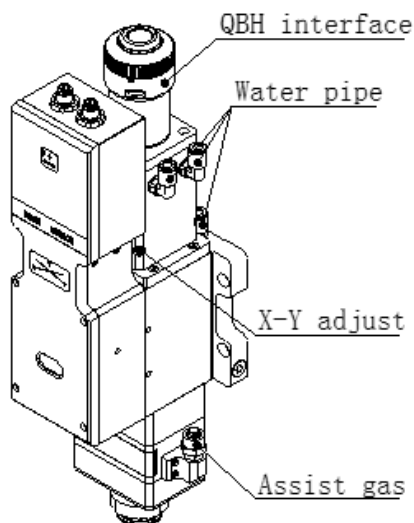
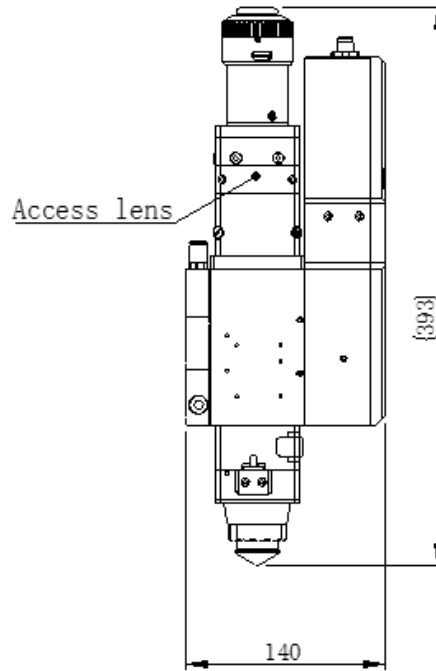
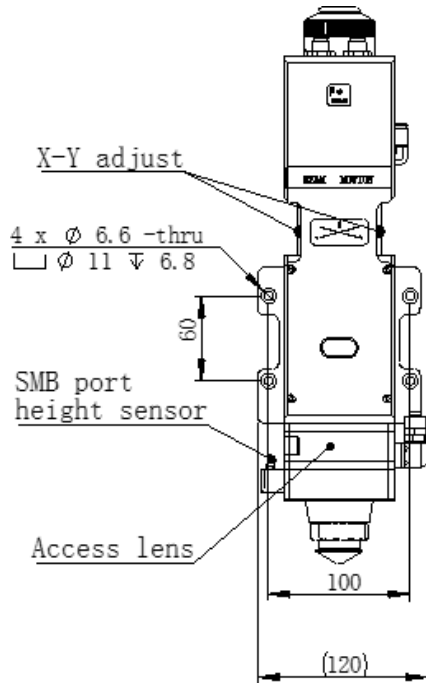

- **Cooling System S&A CWFL-1500**

S&A brand CWFL-1500 water chiller is specially applied to cool the fiber laser and optic lenses at the same time, multiple use for saving cost, space and manual move, quite convenient for the user.

S&A industrial water chiller has 2 temperature control modes as constant temperature and intelligent temperature control. Under intelligent mode, the water temperature is adjusted according to ambient temperature. You do not need to worry about the water temperature adjustment of seasonal changes.



### Industrial water chillers for fiber lasers specification

CWFL-1500	CWFL-1500AN	CWFL-1500BN
Voltage	AC 1P 220 V	AC 1P 220 V
Frequency	50 Hz	60 Hz
Current	3.4~13.7A	3.4~14A
Machine power	2.78 kW	2.76 kW
Electric assisted power	400W + 600W	
Precision	± 0.5°C	
Reducer	Capillary	
Pump power	0.75 kW	
Tank capacity	15L	
Inlet and outlet	Rp1/2"+Rp1/2"	
Lift	53 M	
Rated flow	2 L/min + > 15 L/min	
N.W.	72 Kgs	
G.W.	82 Kgs	
Dimension	70 X 47 X 89 cm (L X W X H)	
Package dimension	74 X 61 X 104 cm (L X W X H)	



Caxtool Kft.  
6791 Szeged, Dorozsmai út 157. EU  
+36 62 254 826  
+36 30 565 1812  
[d.zanocz@caxtool.hu](mailto:d.zanocz@caxtool.hu)  
[info@caxtool.hu](mailto:info@caxtool.hu)

Adószám: 12871856-2-06  
Adószám: HU 12871856  
Bankszámla száma: 57600101-11102986  
SWIFT (BIC): TAKBHUHB  
IBAN: HU65 57600101 11102986 00000000  
cégjegyzékszám: 06-09-014002  
info:

- **CNC Control System FSCUT2000C and Software CypCut**



**FSCUT2000C** laser cutting control system and its **CypCut** software integrates file reading, design, output, and processing control. It's able to complete the entire process from design to processing. The software, installed in an industrial computer, provides a wealth of laser cutting processing parameters, flexible layout and cutting path editing capabilities. CypCut Control system and software in English language, supporting files: DXF, PLT, AI, LXD, etc. Drawing in the software is possible. Software is with fly cutting mode for cutting same products to save time. The nesting function automatically arranges graphs to leave minimum spaces and save materials.





Caxtool Kft.  
6791 Szeged, Dorozsmai út 157. EU  
+36 62 254 826  
+36 30 565 1812  
[d.zanocz@caxtool.hu](mailto:d.zanocz@caxtool.hu)  
[info@caxtool.hu](mailto:info@caxtool.hu)

Adószám: 12871856-2-06  
Adószám: HU 12871856  
Bankszámla száma: 57600101-11102986  
SWIFT (BIC): TAKBHUHB  
IBAN: HU65 57600101 11102986 00000000  
cégjegyzékszám: 06-09-014002  
info:

- **Transmission System**



Machine is with Taiwan YYC gear rack and PMI linear rail transmission, which ensures machine high speed movement, precision and stability as well.

- **Driving system: Yaskawa servo, SHIMPO reducer**



Az alkalmazott servo motorok Yaskawa servo motors and drivers. X, Y1, Y2: Yaskawa 1300W. Z: Yaskawa 400W.

- **Auto Lubrication**



It automatically lubricates guide rails, which ensures the machine keep moving smoothly and with good precision.

- **Exhaust System**



A 2.2Kw centrifugal exhaust fan strongly removes the fumes and dusts caused during cutting.



- **Gas Assist Valves (Solenoid Valve, SMC Proportional Valve)**



Gas assists cutting either in cutting speed, cutting thickness or cutting effect.

For example, oxygen helps to cut faster and thicker; nitrogen helps to get brighter cutting edge.

The solenoid valve controls the gas blowing. Gas blows only during cutting, which saves your gas cost. SMC proportional valve controls the gas pressure and brings good cutting all the time, for example, gas pressure is lowered when cutting corners.

- **Machine Body**



- **Machine Table**

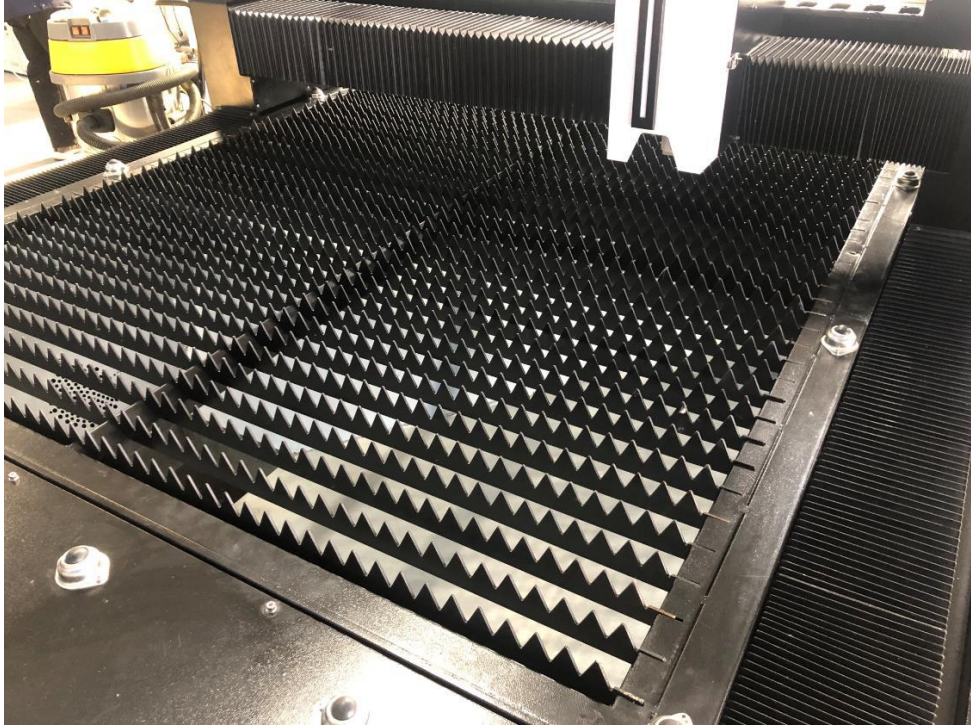

Saw-shape machine table holds metal sheet steady with little touch with metal sheet. The saws are thick and durable. Machine table size is 1500mm by 3000mm.

- **Full cover with CE security glass**

In front door, the glass is CE security glass. Machine left and right side, they are normal glasses.







Caxtool Kft.  
6791 Szeged, Dorozsmai út 157. EU  
+36 62 254 826  
+36 30 565 1812  
[d.zanocz@caxtool.hu](mailto:d.zanocz@caxtool.hu)  
[info@caxtool.hu](mailto:info@caxtool.hu)

Adószám: 12871856-2-06  
Adószám: HU 12871856  
Bankszámla száma: 57600101-11102986  
SWIFT (BIC): TAKBHUHB  
IBAN: HU65 57600101 11102986 00000000  
cégjegyzékszám: 06-09-014002  
info:

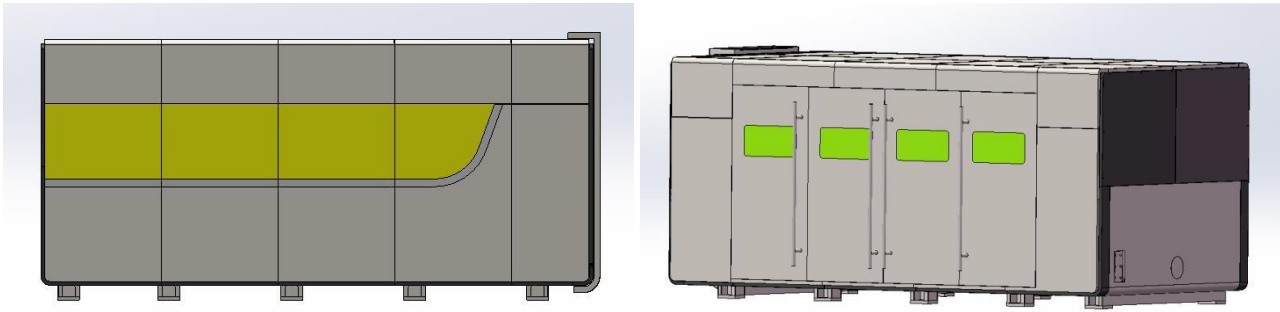

- **Material Loading System**

The machine has folding doors at right side, through which you can load the metal sheets to the machine table. For easier loading of metal sheet, we build the machine with nylon shaft besides the machine table. The shaft is higher than the machine table and Y-axis movement structure, so the metal sheet won't be blocked. Nylon shaft (instead of metal shaft) will not scratch the metal sheet.

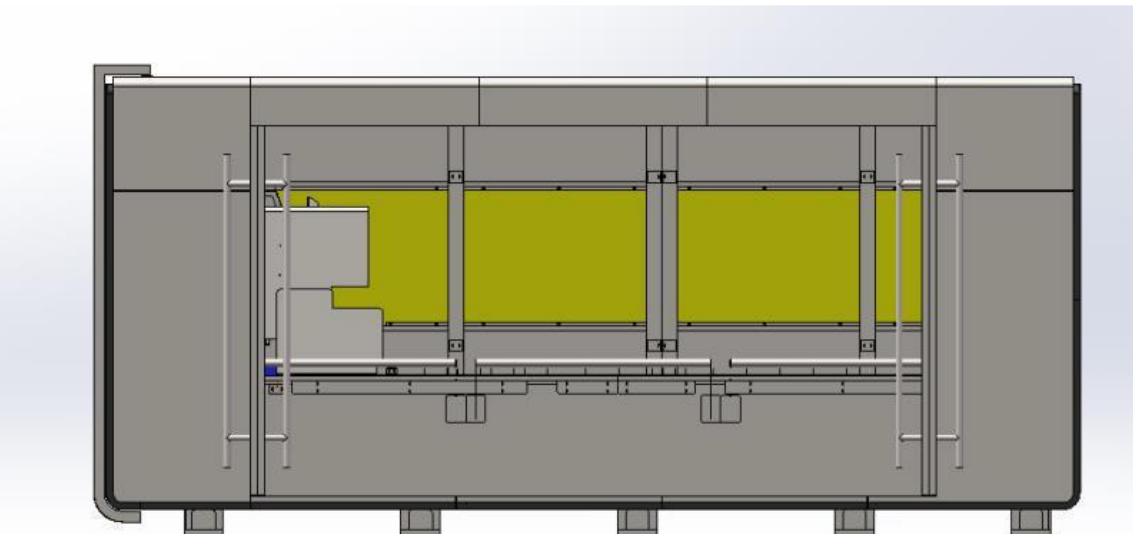
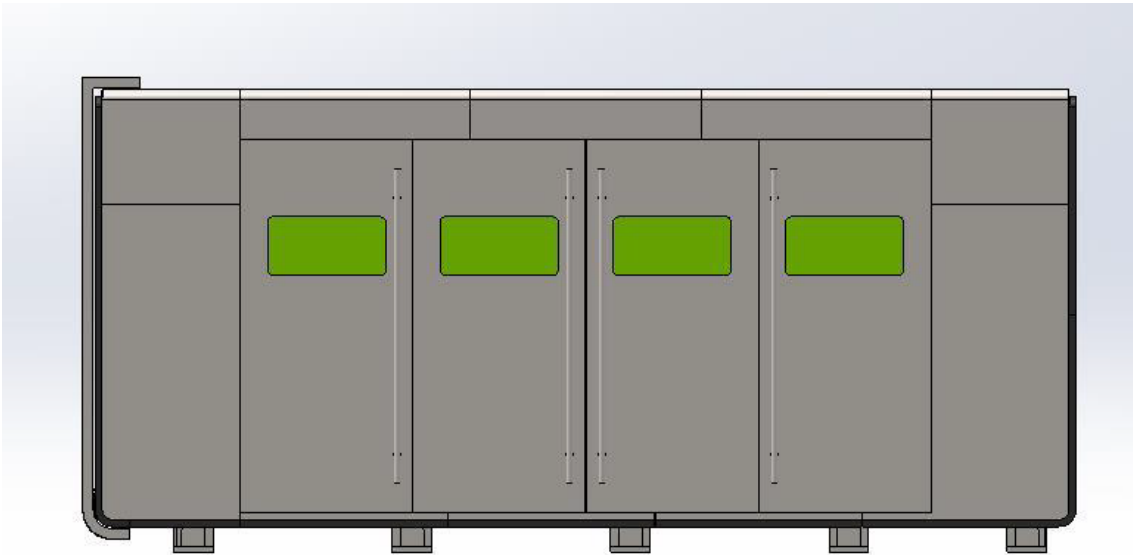

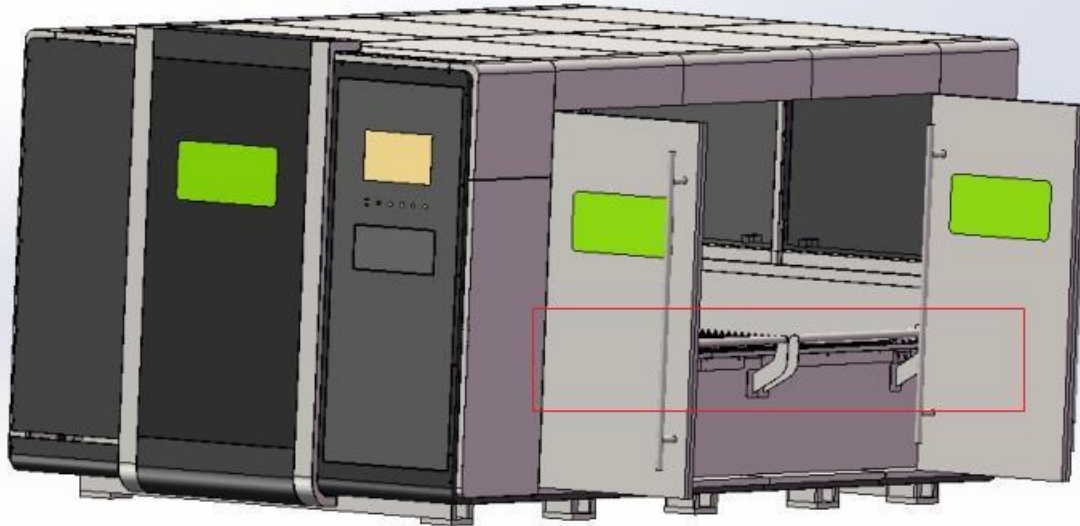

Nylon shaft assisting metal sheet loading

- Safety goggles

