

General Tolerances/Allg.Toleranzen DIN

ISO2768-mk

$0.5 \leq 3$ ± 0.1	$>3 \leq 6$ ± 0.1	$>6 \leq 30$ ± 0.2	$>30 \leq 120$ ± 0.3	$>120 \leq 400$ ± 0.5
---------------------------	--------------------------	---------------------------	-----------------------------	------------------------------

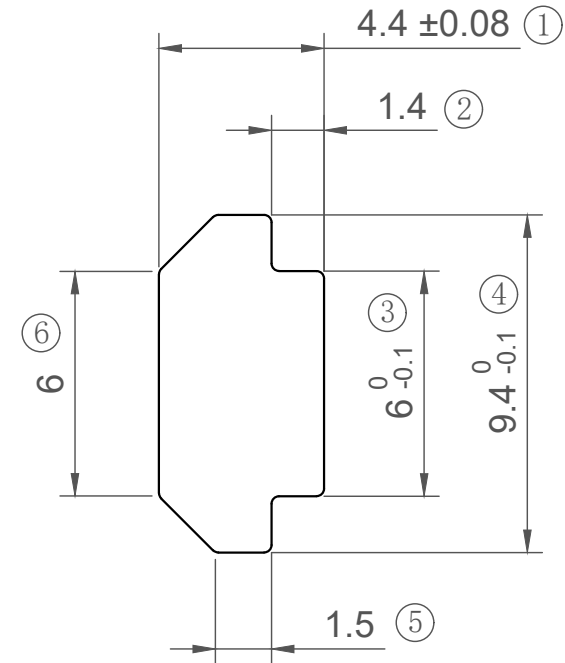
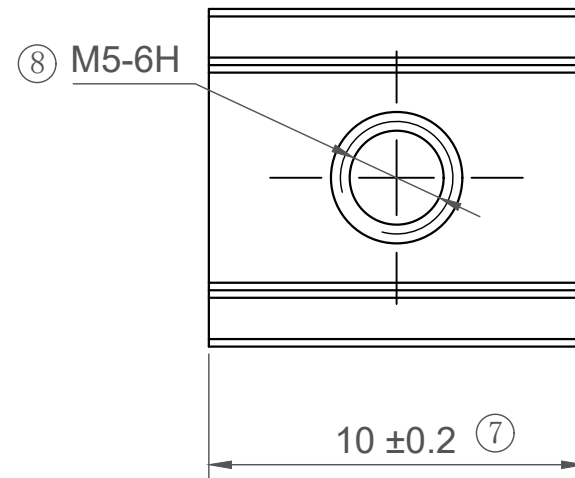
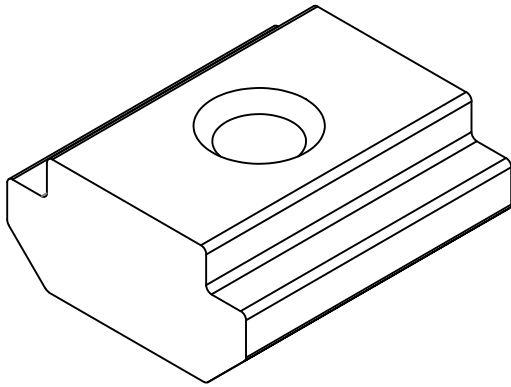

1. Material: Carbon Steel;
2. Surface treatment: Zinc Plated;
3. Appearance should be without lack materials, smudge and burs;
4. Unspecified length tolerance according to 2768-M intermediate tolerance