

General Tolerances/Allg.Toleranzen DIN

ISO2768-mk

$0.5 \leq 3$ $\pm 0.1$	$>3 \leq 6$ $\pm 0.1$	$>6 \leq 30$ $\pm 0.2$	$>30 \leq 120$ $\pm 0.3$	$>120 \leq 400$ $\pm 0.5$
---------------------------	--------------------------	---------------------------	-----------------------------	------------------------------

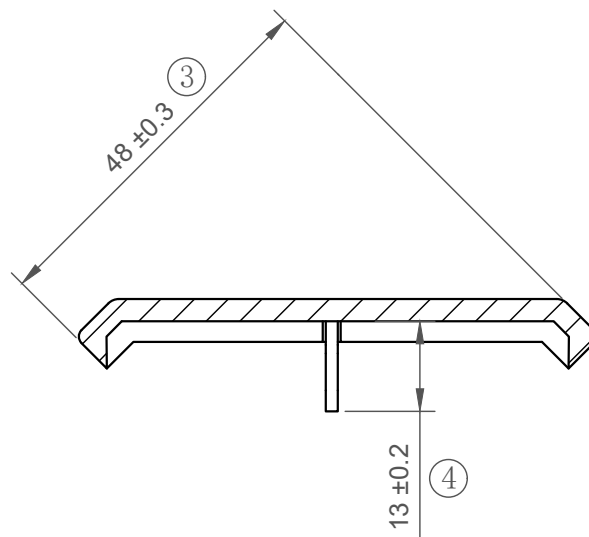
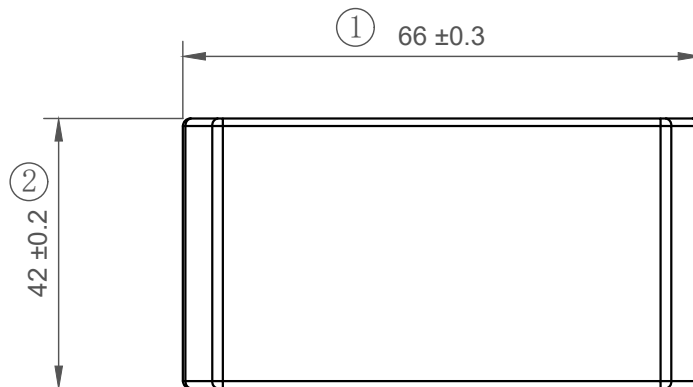
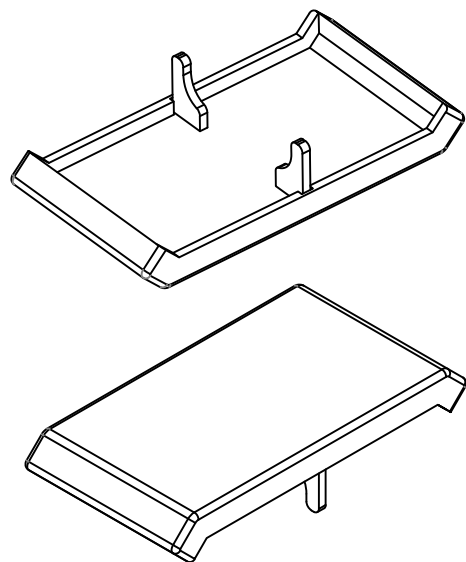

1. Material: Nylon;
2. Surface treatment: Black;
3. Appearance should be without lack materials, smudge and burs;
4. Unspecified length tolerance according to 2768-M intermediate tolerance