

General Tolerances/Allg.Toleranzen DIN

ISO2768-mk

$0.5 \leq 3$ ± 0.1	$> 3 \leq 6$ ± 0.1	$> 6 \leq 30$ ± 0.2	$> 30 \leq 120$ ± 0.3	$> 120 \leq 400$ ± 0.5
---------------------------	---------------------------	----------------------------	------------------------------	-------------------------------

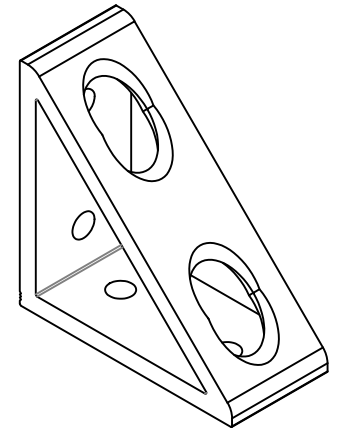
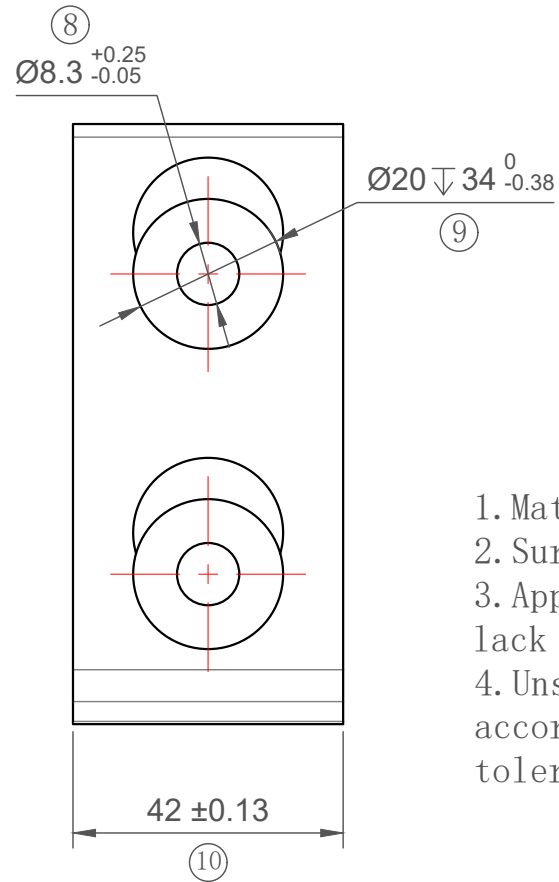
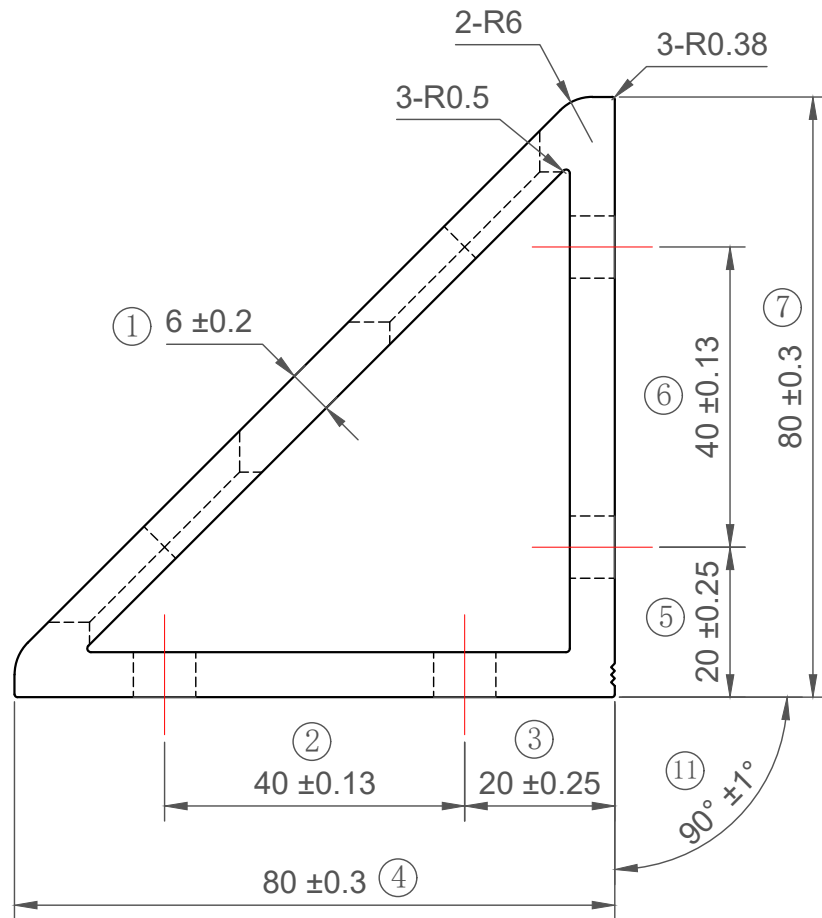

1. Material: 6061-T6;
2. Surface treatment: Anodized;
3. Appearance should be without lack materials, smudge and burs;
4. Unspecified length tolerance according to 2768-M intermediate tolerance