

General Tolerances/Allg.Toleranzen DIN ISO2768-mk

	>0.5≤3	>3≤6	>6≤30	>30≤120	>120≤400
	±0.1	±0.1	±0.2	±0.3	±0.5

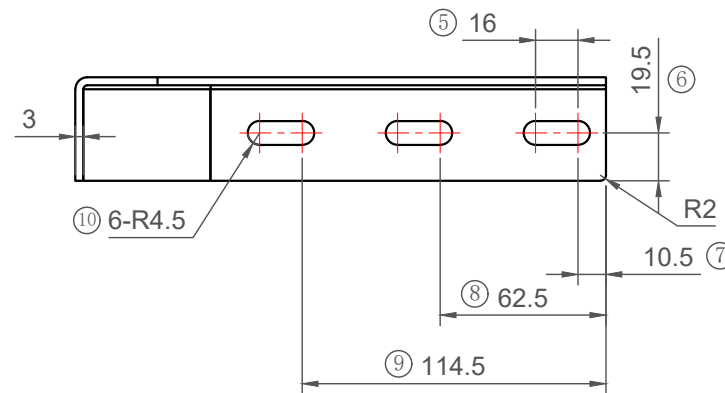
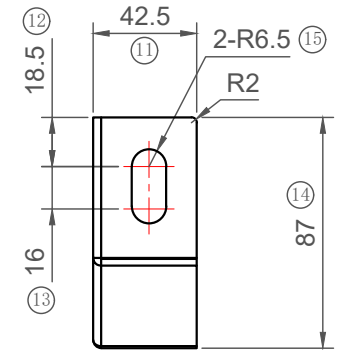
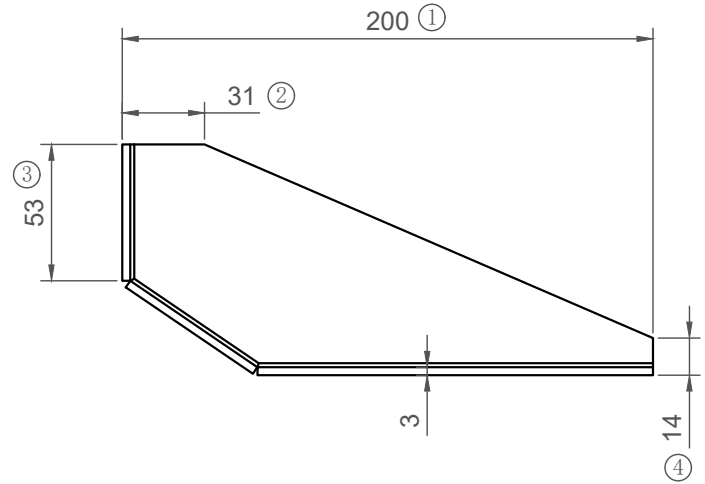
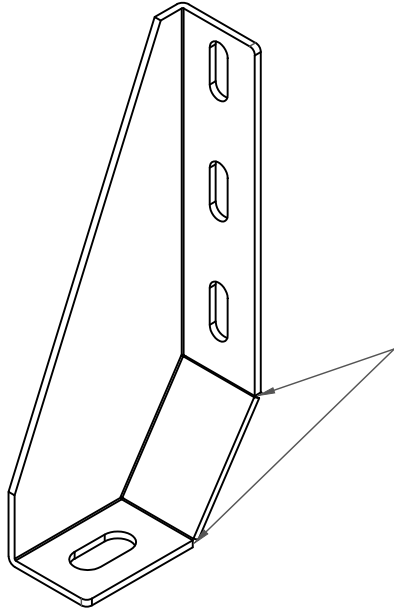

1. Material: Carbon Steel;
2. Surface treatment: Zinc Plated;
3. Appearance should be without lack materials, smudge and burs;
4. Unspecified length tolerance according to 2768-M intermediate tolerance